

**DEMAG**

**MAG**

*With a simple touch  
Great savings  
and more safety*

# **TECNO-LIFT**

**Permanent electro magnetic  
heavy duty lifting systems**



**TECNOMAGNETE®**

**Safety through power**

## TECNO-LIFT

### The most intelligent way to move ferrous loads

Magnetism is the smartest way of handling ferrous loads. Tecnomagnete has continuously researched and developed permanent-electro magnets for 30 years, the only technology that combines safety, strength, convenience and power savings.

Tecnolift systems can handle loads with extreme easiness in the minimum area.

They are efficient because they always operate from the top without compressing or deforming the load.

The floor space is optimized as no empty areas are required around or in between the loads to get access for their pick up.

No other solution can grant the same level of performances and practical use.

TECNO-LIFT is the ideal solution for steel structural works, distribution and storage, service centers, metalworkings, shipbuildings, surface treatment and for all modern industries interested in increasing the efficiency of production process.

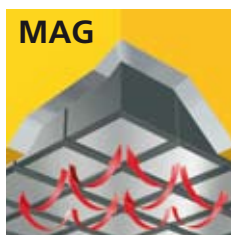

#### Quadsystem technology. Power and safety to square.

Quadsystem permanent-electro circuit: the power of an electromagnet joined to the independence of the permanent magnet.

The technology of the double magnet uses electrical power only for few seconds in activation "MAG" and deactivation "DEMAG" cycles.

Tecnomagnete designed and patented this unique and totally innovative technology, where the clamping surface is composed by square poles in chess-board disposition, able to generate great power exactly and only where it is needed: into the load.

The patented "neutral crown" guarantees a perfect insulation of the permanent magnets, avoiding any power losses and interferences with other metallic objects nearby.

#### Permanent safety

A permanent electro system is intrinsically safe being not affected by any electrical power failure.

No battery back up system is required. The high energy coming from the permanent magnets keeps the load safely clamped with constant force for indefinite period of time and it can be released only on the ground. The maximum safety level for the operator and for the machinery is granted, always!



#### Easy to use and convenient

One single operator with a remote control can perform all picking-up, lifting, handling and releasing operations always staying at safe distance from the load.

No other manpower is required near the load. No other safety tools, belts, chains need to be managed and maintained.



## Advantages versus the traditional electro-magnetic technology

### Constant strength

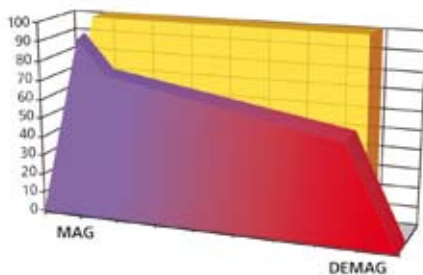

### High energy saving

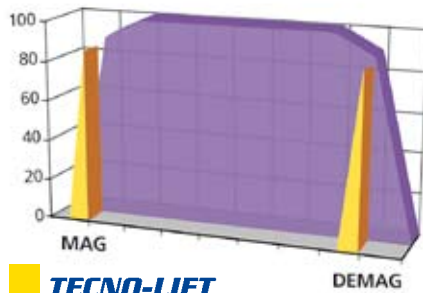

**TECNO-LIFT**

■ Electro magnet  
■ Heating effect with electro magnet

Tecnolift permanent electro technology is a great leap ahead compared to the traditional electro magnetic lifters:

**In performance:** TECNO-LIFT is a cold system due to the absence of heat generation inside the magnets. The clamping force remains constant unlike the traditional electromagnets that are affected by the overheating of the coils in constant use.

**In energy saving:** TECNO-LIFT needs electrical supply only for few seconds, during the MAG and DEMAG phases. The electrical consumption is 95% less compared to a traditional electromagnet.

### In operational costs:

The robust solid block construction of Tecnolift magnetic modules with no moving parts inside, no stress and no overheat in the magnet coils can grant a long reliability without specific maintenance. The expensive back up maintenance is also avoided.

### In the production process:

TECNO-LIFT doesn't leave residual magnetism in the load. All problems caused normally by the residual magnetism on welding or precision machining operations are eliminated.

## Flux concentration for a precise lifting

The Quadsystem technology allows to short circuit the magnetic flux within a very small depth making possible to lift one steel plate only even when limited thickness are involved.



### Load stability and compactness.

The traditional wooden spacers between loads are no more necessary. The load condition is more compact, less overall size and, with no deformation it is more stable during the transportation.

## Tailored Solutions

Tecnolift systems are designed and built to be compact, light weight, powerful and reliable.

The vast array of standard models provides various characteristics of polar geometry and magnetic strength to achieve the correct performance with relation to the load type to be handled (plates, blocks, slabs, profiles, coils, etc...)

All standard Tecnolift systems grant a safety factor of 1:3 between the weight of the load at its operative air-gap and the relevant magnetic force of the lifter.

## Certified Quality

The Tecnolift systems respect the most common international norms. (UNI-EN 13155:2004). Manufacturing quality control, operating safety and constant performances are tested and certified.



# Sheet handling



## Telescopic beams

Plates, especially large ones, are particularly difficult load to handle. When attempting to move with traditional methods (hooks, chains, cables) the plates have a tendency to flex and deform, making the grip on the load unstable and dangerous.

The TM series beams pick up the load uniformly from above, without deformations or damage to the load. Specific selection of the thickness is possible even via radiocontrol to pick up single plate.



### TM 4 series

For single plate handling up to 12m. Version with 4 cross beams with 2 modules each

### The Telescopic Movement



The ability to lengthen or shorten the center distance between cross beams and select the modules to magnetize, make the TM beams extremely flexible to use. The telescopic movement is actuated by a dedicated hydraulic pump; the movement of the telescopic arms allows the handling of a complete range of big plates.



- medium plates: activate all the cross beams with the side modules in the closed position
- long plates: activate all the cross beams and extend the arms to the maximum opening
- narrow plates: activate only the left or right side modules

Model	beam weight kg	Load Characteristics				rated lift capacity max kg	
		thickness. min. mm	length min. mm	length max mm	width min. mm		width max mm
TM 4/75 N	3000	5	3000	12000	500	2500	7500
TM 4/100 N	3000	5	3000	12000	500	3500	10000
TM 4/120 N	3000	5	3000	12000	500	3500	12000
TM 4/140 N	3000	8	3000	12000	500	3500	14000
TM 4/180 N	3000	8	3000	12000	500	3500	18000

### Modules Selection

It is possible to lift loads of various lengths, by simply selecting the magnetic modules necessary:

- shorter plates: activate only the center cross beams, excluding the others

### Air Gap Curve

on flat surface in "Fe" minimum thickness 30mm with all poles covered. Temp. < 100°C

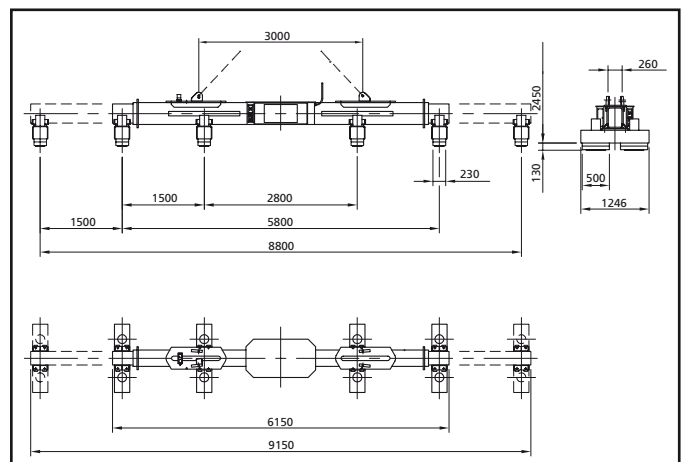
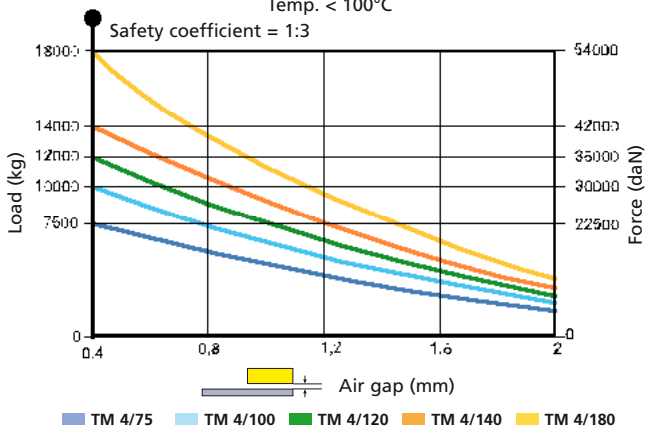



**TECNOMAGNETE®**



## TM 6 series

For handling single plates up to 16m.  
Version with 6 cross beams with 2 magnetic modules each

### Whip Chart

The TECNO-LIFT lifting systems are designed with rigid structural characteristics and with a specific magnetomotive force coefficient (MMF) to guarantee handling even with significant values on the whip chart.

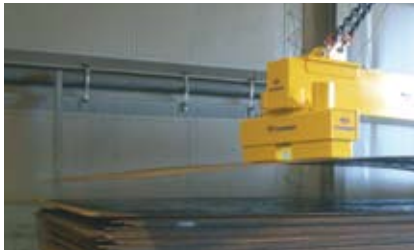

With the TECNO-LIFT systems it will be always possible to obtain the utmost performance in terms of load capacity and size, as specified in the technical specifics of these tables and performance tags on the lifters.

TM beams are available in TG version (6 or 8 cross beams) to handle sheets with thickness from 4 mm and capacity up to 10.000 kg.

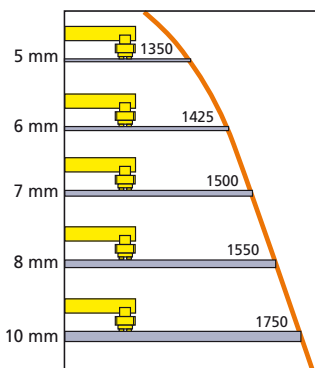

Allowed whip chart values: the relationship between the end of the load ("wing") and the thickness of the same piece.

### Air Gap Curve

on flat surface in "Fe" minimum thickness 30mm with all poles covered.  
Temp. < 100°C

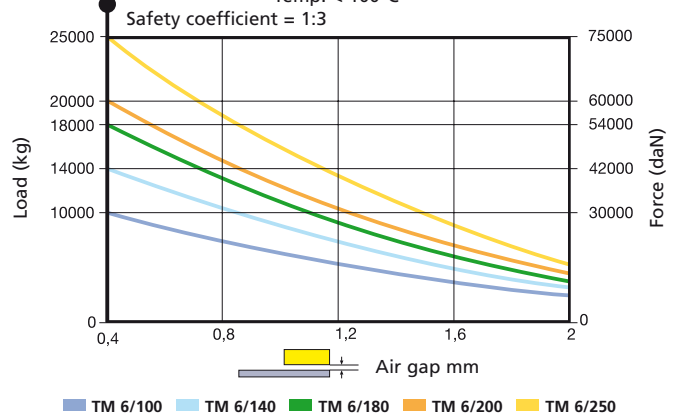

Model TM 6/N	beam weight kg	thickness		length		width		rated lift capacity max kg
		min. mm	max mm	min. mm	max mm	min. mm	max mm	
TM 6/100 N	4000	5	8	2800	16000	500	2500	10000
TM 6/140 N	4000	5	8	2800	16000	500	3500	14000
TM 6/180 N	4000	5	8	2800	16000	500	3500	18000
TM 6/200 N	4000	8	8	2800	16000	500	3500	20000
TM 6/250 N	4000	8	8	2800	16000	500	3500	25000

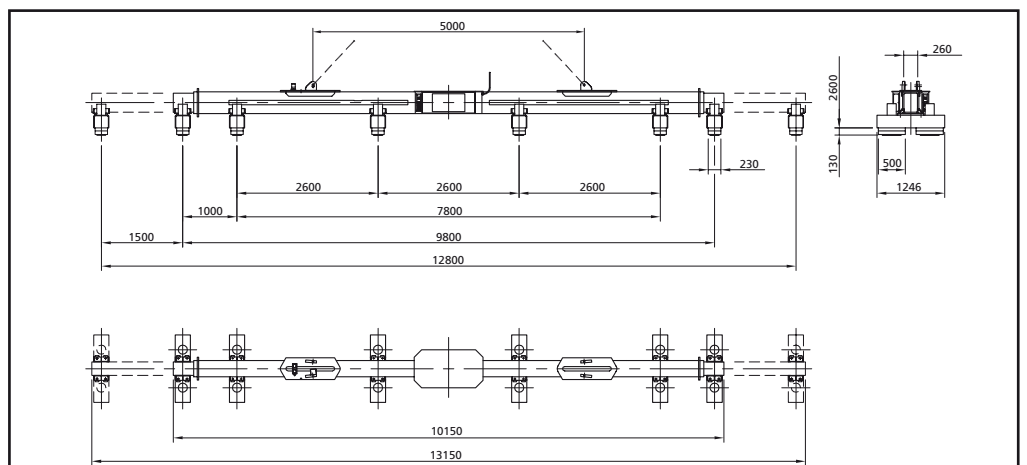

# Sheet handling



## BF 2 Fixed Beam

For plates handling with a maximum length of 6 m.  
2 cross beams with 2 magnetic modules each

They have the same characteristics as the TM series, but the 2 cross-beams are at fixed distance.  
This system is used when the plates come in constant sizes and do not require the telescopic device.



BF /TG version available for loads with thicknesses from 1,5 mm



BFS with multiple cross beams for standard strips handling

### Air Gap Curve

on flat surface in "Fe" minimum thickness 30mm with all poles covered.  
Temp. < 100°C

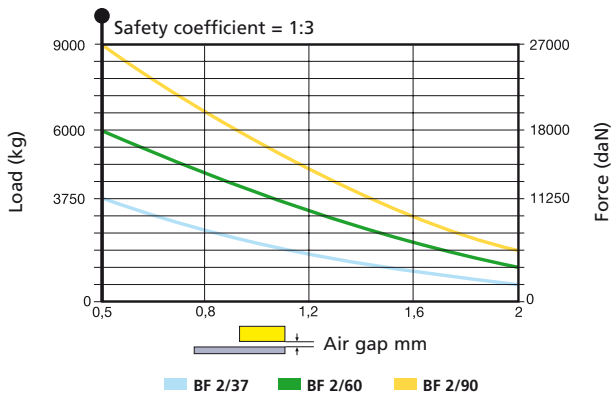

Model	beam weight kg	Load Characteristics				rated lift capacity max kg
		thickness. min. mm	length max mm	width min. mm	width max mm	
BF 2/37	1300	5	3200	500	2500	3500
BF 2/60	1300	5	3200	500	3500	6000
BF 2/90	1300	8	3200	500	3500	9000

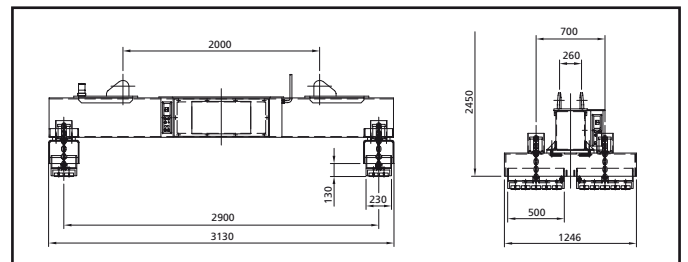

## GTR Magnetic Cross-beams

The magnetic cross-beams come separate without beams in sets of 4 or 6 (respectively GTR 4/N and GTR 6/N) complete with controller and accessories, ready to be installed on existing beams.  
Magnetically equivalent to TM 4/N and TM 6/N

Model	weight kg	Load Characteristics				rated lift capacity max kg
		thickness. min. mm	length max mm	width min. mm	width max mm	
GTR 4/75 N	1250	5	12000	500	2500	7500
GTR 4/100 N	1250	5	12000	500	3500	10000
GTR 4/120 N	1250	5	12000	500	3500	12000
GTR 4/140 N	1250	8	12000	500	3500	14000
GTR 4/180 N	1250	8	12000	500	3500	18000



Model	weight kg	Load Characteristics				rated lift capacity max kg
		thickness. min. mm	length max mm	width min. mm	width max mm	
GTR 6/100 N	1875	5	16000	500	2500	10000
GTR 6/140 N	1875	5	16000	500	3500	14000
GTR 6/180 N	1875	5	16000	500	3500	18000
GTR 6/200 N	1875	5	16000	500	3500	20000
GTR 6/250 N	1875	8	16000	500	3500	25000



**TECNOMAGNETE®**



## TB Tilting beams

For handling single plates up to 12 m. long in vertical or horizontal position.

The fix beam with the simple and effective tilting system of the magnetic modules is the perfect solution for operations where vertical axis plates need to be placed in a horizontal axis or vice versa (typically from storage to a cutting table, laser, plasma, etc...)

Supplied with a special radio remote control "belt use" RC/B.



Model TB	Load Characteristics				rated lift capacity max kg
	thickness. min. mm	min. mm	length max mm		
TB 4/35	4	2500	6000		3500
TB 6/35	4	2500	12000		3500
TB 2/60	8	2500	6000		6000
TB 4/120	8	3000	12000		12000

## TT Fix beams for cutting systems

Fix beams for cutting systems

For handling single plates and skeletons after the cutting operation is completed.

TT modular systems are tailor made by designing them to the size of the plate and the cut pieces.

They allow easy and fast loading & unloading operations on any type of cutting machines (plasma, oxyacetylene, laser, high definition). In particular they free the bench from cut plate and skeleton in a single move to make the machine immediately available.

**Other versions:**

TT/L for laser cutting systems; minimum piece size 70x70 mm, min thickness 2 mm.

TT/H for heavy weight pieces



**TT /O** Standard model for any sheet surface with a minimum piece size of 300x300 mm. and a thickness between 4 and 25 mm.

Model TT /O	weight kg	Load Characteristics				
		piece min mm	thickness min - max mm	length max mm	width max mm	rated lift capacity max kg
TTO /045	1850	300x300	4 - 25	1500	3000	1000
TTO /060	2200	300x300	4 - 25	1500	4000	1200
TTO /080	2900	300x300	4 - 25	2000	4000	2000
TTO /100	3400	300x300	4 - 25	1500	6600	2000
TTO /120	3800	300x300	4 - 25	2500	5000	3000
TTO /150	4600	300x300	4 - 25	2500	6000	3000

# Block handling



## SML single modules

For handling single plates or semi finished blocks.

SML permanent electro-magnetic modules are the ideal answer for handling blocks with limited air gap.

- Excellent ratio between weight of the lifter and its capacity.
- Multipole circuit to uniformly spread the force across the working area.



### Air Gap Curve

on flat surface in "Fe" minimum thickness 30mm with all poles covered.  
Temp. < 100°C

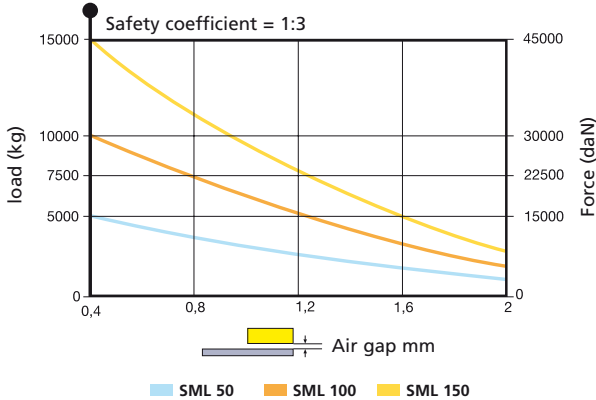

Model SML	module weight kg	thickness. min. mm	Load Characteristics				rated lift capacity max kg
			length mm		width mm		
SML 50	500	8	min. 1000	max. 5000	min. 1000	max. 3000	5000
SML 100	700	8	min. 1000	max. 5000	min. 1000	max. 3000	10000
SML 150	700	8	min. 1000	max. 5000	min. 1000	max. 3000	15000

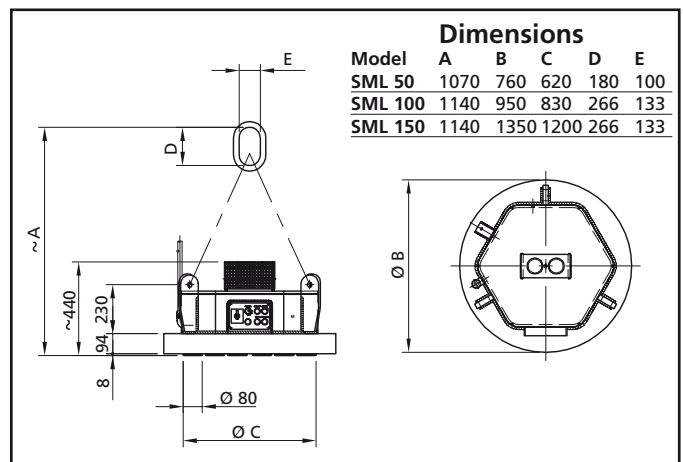





**TECNOMAGNETE®**

## SMH single modules

For handling single thick slabs and forged blocks.

SMH permanent electro-magnetic modules are designed for lifting loads with big operational air gaps.

- 4-pole circuit for high force concentration.
- High magnet strength.



### Air Gap Curve

on flat surface in "Fe" minimum thickness 100 mm with all poles covered.  
Temp. < 100°C

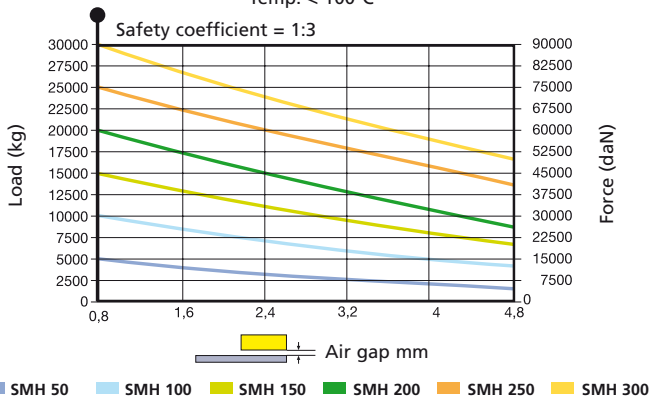

### Dimensions mm

Model	A	B	C	D	E	F Ø	G	H	I	L
SMH 50	1285	505	155	198	462	800	180	100	15	
SMH 100	1545	531	181	242	560	880	266	133	15	
SMH 150	1575	563	213	280	626	860	266	133	15	997
SMH 200	1760	577	227	320	706	980	304	152	15	1117
SMH 250	1790	637	280	350	770	1100	355	177	18	
SMH 300	1790	625	272	374	814	1147	355	177	18	1311

Model SMH	module weight kg	Load Characteristics			
		thickness. min. mm	length min. mm	width min. mm	rated lift capacity max kg
SMH 50	610	30	1000	6000	5000
SMH 100	950	30	1000	6000	10000
SMH 150	1300	40	1000	6000	15000
SMH 200	1750	40	1000	6000	20000
SMH 250	2150	80	1000	6000	25000
SMH 300	2700	80	1000	6000	30000

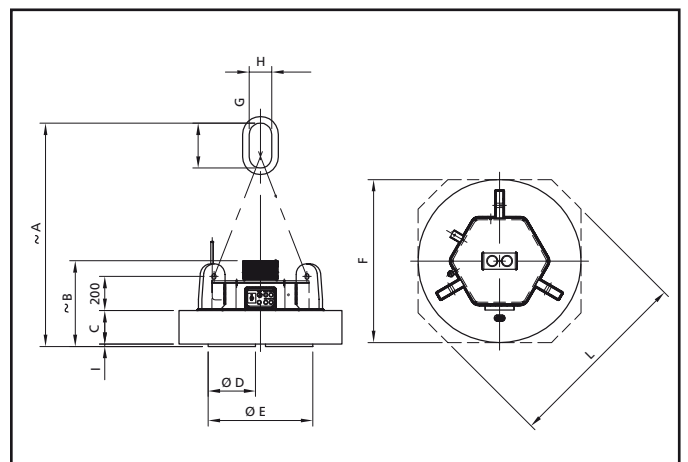

# Coils - Billets and Slabs handling



The TECNO-LIFT line provides a vast array of solutions dedicated for the handling of compact coils of various morphology and dimensions, without weight limitations.

TECNO-LIFT always comes in contact with the material surface gently from the top, without compression or deformations.

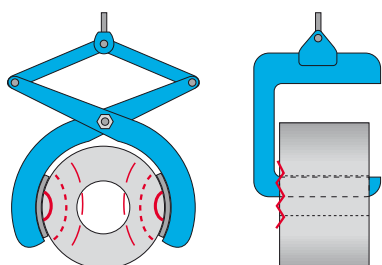

TECNO-LIFT avoids all the problems associated with conventional methods of lifting represented by clamps and C-hooks which require constant pressure on the load.



## CH

Modules for handling cold-rolled coils with a horizontal eye. Complete with automatic load-centering system.

## CV / T

Modules for handling cut coils, vertical eye (slitting lines).



## CV

Modules for handling cold-rolled coils, vertical eye.



## CO

Modules for handling open coils, vertical eye (annealing process).



Model CV / T	weight kg	Load Characteristics			
		Ext. Ø min - max mm	Int. Ø max mm	Height min - max mm	rated lift capacity max kg
CV / T 10	500	560-1000	460	140-300	1000
CV / T 15	565	800-1300	610	50-250	1500
CV / T 30	610	600-1150	508	20-500	3000
CV / T 40	1200	800-1450	508	30-500	4000
CV / T 50	1500	800-1800	508	30-500	5000



**TECNOMAGNETE®**



## **BL**

Permanent-electro magnetic modules for handling layers of billets up to 600° C – in the core.

### **Versions:**

**BL /S** single module for billets up to 6.000 mm length

**BL /D** double modules for billets up to 12.600 mm length



## **BR**

Modules for handling slabs  
Typical application: on harbour cranes, to load/unload ships.

### **Versions:**

**BR /S** single module for slabs with length 1.000 - 8.000 mm

**BR /D** double modules for slabs with length 6.000 - 12.000 mm

**BR /W** "twin" module with mechanical auto-levelling system for loads 6.000 - 12.000 mm length

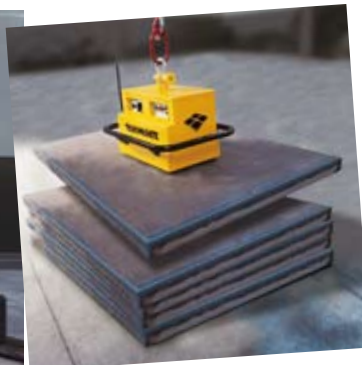

## **BAT GRIP**

3 Ton capacity permanent-electro lifters with battery.

Equipped with a remote control, this lifter is capable to be used for a long period independent of the power supply (est 7 days), because the energy is only used for a fraction of a second during the MAG/DEMAG phase.

# Sections - Rails - Profiles - Rounds - Pipes - Tanks



## RD

Modules for lifting rounds.

For the movement of round loads only. The modules "V" groove design adapts to the morphology of the load allowing the centering of the module on the load during clamping phase.

Model RD	weight kg	Load Characteristics		
		Diameter min - max mm	length min - max mm	rated lift capacity max kg
RD 20	250	280-400	800-2000	2000
RD 25	400	200-600	600-2000	2500
RD 35	1000	100-350	1000-6000	3500
RD 60	1000	350-810	1000-2000	6000
RD 80	1500	300-700	1000-5000	8000
RD 100	2700	310-1000	1500-7000	10000
RD 150	2800	310-1200	1500-7000	15000

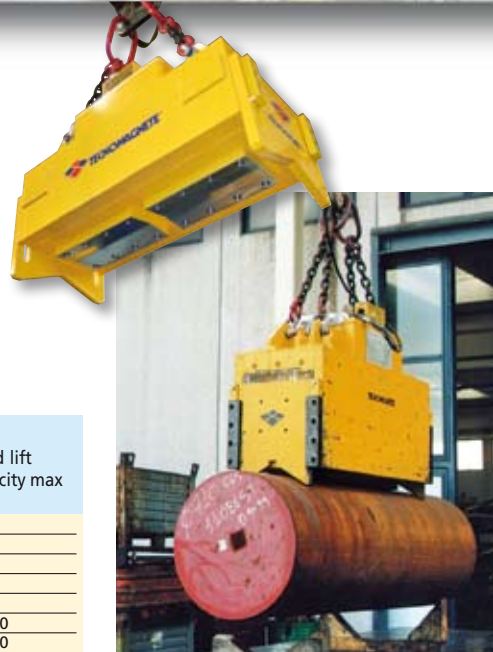

RDP version available for polygonal and irregular shape loads

## CS

Modules for lifting tanks.

For the movement of round loads of oversized dimensions and thin wall thickness. Tailor made solutions for the movement of tanks, containers, in total safety without deformation of the load.



## TU

Modules for lifting tubes - round and square.

For the lifting of layers of tube without welding and round loads of various types





### TP

For handling beams and profiles.

Modular systems combining the benefits of safe lifting, compactness and convenience. Their specific and unique pole design permits the rotation of the load on the ground for the inspection or for the storage in the correct position between the racks.



Model TP	weight kg	Load Characteristics		
		HEA - HEB - IPE - IPN min - max mm	length min - max mm	rated lift capacity max kg
TP 1/100	400	80-600	1000-6000	1000
TP 2/200	1000	80-600	6000-12000	2000
TP 2/400 TW	1200	80-600	3000-18000	4000
TP 3/200	1250	80-600	1000-12000	2000
TP 4/400	1600	80-600	6000-18000	4000
TP 5/400	1900	80-600	1000-18000	4000
TP 6/400	2100	80-600	3000-24000	4000

## Dedicated solution

The TECNOMAGNETE can be equipped with accessories for various applications:

- **MRS - Fifth wheel**  
to rotate the load according to the application.

- **4HV - Supplementary hooks**  
Allow the use of the beam in a traditional manner, with chains and rope, without dismantling the TECNOMAGNETE system. Useful when the load is non ferrous or has non-standard geometry.

- **SRM**  
Manual 90° rotation system for the cross-beams. Useful for profiles and narrow loads.

- **DPV - Ring to the hook combination**  
Allows the use of the beam alternately with single and double crane hoists. Chains and ring housing built-in.



# Characteristics, Accessories and Equipments



When it comes to safety and trust, no detail can be overlooked or left to chance: thousands of TECNO-LIFT systems installed all over the world are our main credentials. Every system represents a study in optimizing the function of real time productivity.

Special attention is dedicated to the safety: various electromechanical systems check for accurate magnetism on the load and detect any problems that may occur during the magnetization, clamping of load, moving the load and the accidental demagnetization during the material handling.

with 75% of the total possible magnetization strength, only once the load is lifted from the ground the second MAG cycle is executed allowing 100% of the total magnetization power (FULL MAG). This provides a definite minimum safety margin to the load that can be handled in complete safety.



All the magnetic modules are made from a solid piece of steel; this creates a greater protection against accidental impacts with higher reliability. Elastic suspension system are used since the application requires it to equally distribute the weight of the load among the different pick up points avoiding dangerous overloading.

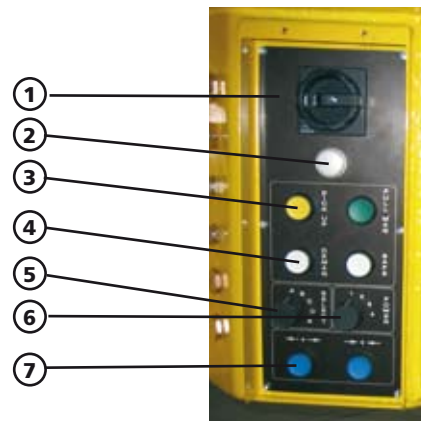

## Control Unit

In a compact IP54 cabinet to allow fast activation and deactivation cycles (max 7 sec)

### 1- Push button panel

Is integrated in the body of the lifter and contains the basic functions (ON/OFF, PICK-UP, FULL MAG, DEMAG, SAFE)

**2- The electronic UCS saturation control system** controls the correct value of the current absorbed to ensure that the modules reached the full magnetic saturation.

### 3- PICK-UP, FULL MAG\*

The TECNO-LIFT system uses a double magnetization cycle test the load according to its weight and airgap condition. Pick-up cycle is executed first

**4- Safe button:** The user is obligated to press 2 buttons at the same time (SAFE and DEMAG) to release the load, this reduces the chances of an accidental load release.

**5- Cross Beam Selections\*.** Allows the magnetization pattern of the modules: only the center ones, all the cross beams, only one side (narrow loads) left or right.

**6- The push button remote** includes the **APC Power adjustment control.** This is a 4 level selector that can reduce the magnetic depth to pick up the load from stack.

**7- For the TM4 and TM6 systems,** the remote control also includes the **OPEN and CLOSE** buttons for the telescopic portions of the beams.

\*only available for specific TECNOLIFT models – see chart)



**TECNOMAGNETE®**

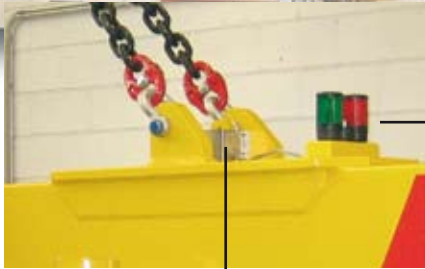

**DAUTANAC**

Is the safety contact that allows the magnetization / demagnetization only when the chains are slack. This contact prevents the accidental demagnetization when the load is suspended.

**Chains:**  
are high strength steel 80.

**Lamp Block**

To display the status of the system: Normal operation / Pick Up phase / Alarms



**Drum Reel**

Enables an easy installation of the system on any type of crane. The cable length is 12 meters and it comes with the appropriate mounting plate.



**RC / N**

**Remote Control**

Enables the operation of the system (pickup/ full mag/ safe/ open/ close) from outside the working area and away from the load.

The new model is ergonomic, with emergency stop button and APC power adjustment knob. Supplied with frequency regulator, two re-chargeable batteries and charger (110V or 220V) for the transmitter.

RC / S: simple remote control  
RC / B: "belt use" remote control

**Cross Beam magnetization selector**

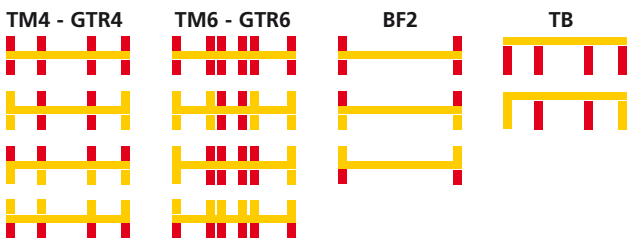

**Standard supply table**

	Standard ●																Optional □		
	TM4	TM6	BF2	GTR4	GTR6	TB	TT	SML	SMH	CV	CO	CH	BL	BR	BAT	TP	RD	TU	CS
Structure - High strength tubular steel	●	●	●	□	□	●	●	-	-	-	-	-	□	□	-	●	-	●	●
Elastic suspension system for modules	●	●	●	●	●	●	-	-	-	-	-	-	-	-	-	●	-	●	-
Integrated control Unit	●	●	●	-	-	●	●	●	●	-	-	-	-	-	-	●	●	●	●
Stand alone controller	-	-	-	●	●	-	-	□	□	●	●	●	●	●	-	□	□	□	□
Double cycle magnetization PICK-UP/FULL MAG	●	●	●	●	●	●	●	●	●	●	●	●	●	●	-	●	●	●	●
Hydraulic telescoping system	●	●	-	-	-	-	-	-	-	-	-	-	-	-	-	-	-	-	-
Remote control RC/*	N	N	N	N	N	B	N	N	N	-	-	-	-	-	S	N	-	-	-
Remote control for crane cabine	-	-	-	-	-	-	-	□	□	□	□	□	□	□	-	□	□	□	□
APC power adjustment	●	●	●	●	●	●	●	●	●	□	-	-	-	□	-	-	□	□	□
Safe Button	●	●	●	●	●	●	●	●	●	●	●	●	●	●	-	●	●	●	●
DAUTANAC	●	●	●	●	●	●	-	●	●	●	-	-	□	●	●	-	-	-	-
UCS Saturation control unit	●	●	●	●	●	●	●	●	●	●	●	●	●	●	●	●	●	●	●
Lamp Block	●	●	●	●	●	●	●	●	●	●	●	●	●	●	-	●	●	●	●
Chains	●	●	●	□	□	●	●	●	●	●	●	●	●	●	-	●	●	●	●
Drum Reel	□	□	□	□	□	□	□	□	□	□	□	□	□	□	-	□	□	□	□
Installation kit	□	□	□	□	□	□	□	□	□	□	□	□	□	□	-	□	□	□	□
SRM - Module rotation device	□	□	□	□	□	-	-	-	-	-	-	-	-	-	-	-	-	-	-

Please visit our website to download technical questionnaires.



# A world of magnetic solutions

Here is a strong statement:  
Tecnomagnete has revolutionized the world of work holding!  
Do you want a stronger one? The QuadSystem!

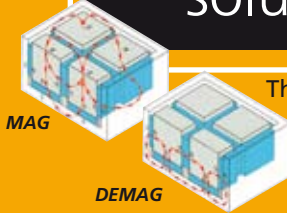

This permanent electro magnetic system generates a concentrated and predetermined force that is highly effective to clamp steel parts on machine tools, moulds for injection molding and dies for metal stamping machines, and the handling of ferrous loads.

We've believed in the force of our QuadSystem patent and many companies have believed in this powerful innovative technology. The large variety of applications of over 100,000 systems sold world wide gave all our customers a sharp competitive edge with safety and flexibility.

Nowadays, with the global network of our subsidiaries and commercial partners we are at your disposal to show you state of the art technical solutions for all applications and increase your success.

***Tecnomagnete: all the magnetism of the leader.***

We reserve the right to make changes related to the technological progress.

TL ENG-02/09

Headquarters:  
**TECNOMAGNETE spa**  
20020 Lainate (MI) Italia, Via Nerviano 31  
Tel. +39 02.937.591, Fax +39 02.935,708.57  
e-mail: info@tecnomagnete.it

[www.tecnomagnete.com](http://www.tecnomagnete.com)



**TECNOMAGNETE®**  
**Safety through power**

- Subsidiaries:
- France Tecnomagnete S.A.R.L.
  - Germany Tecnomagnete GmbH
  - Sweden Tecnomagnete A.B.
  - USA Tecnomagnete Inc.
  - Japan Tecnomagnete Ltd
  - China Tecnomagnete Shanghai R.O.
  - Singapore Tecnomagnete Singapore R.O.
  - Korea Tecnomagnete Seoul R.O.
  - India Tecnomagnete Mumbai R.O.

Distributor: